



56ª COGEF

Comissão de Gestão Fazendária

NOVO MODELO DE FISCALIZAÇÃO TRIBUTÁRIA de MERCADORIAS EM TRÂNSITO

MATO GROSSO DO SUL



COORDENADORIA DE FISCALIZAÇÃO
DE MERCADORIAS EM TRÂNSITO

SEFAZ
Secretaria de
Estado de
Fazenda



ORGANIZAÇÃO

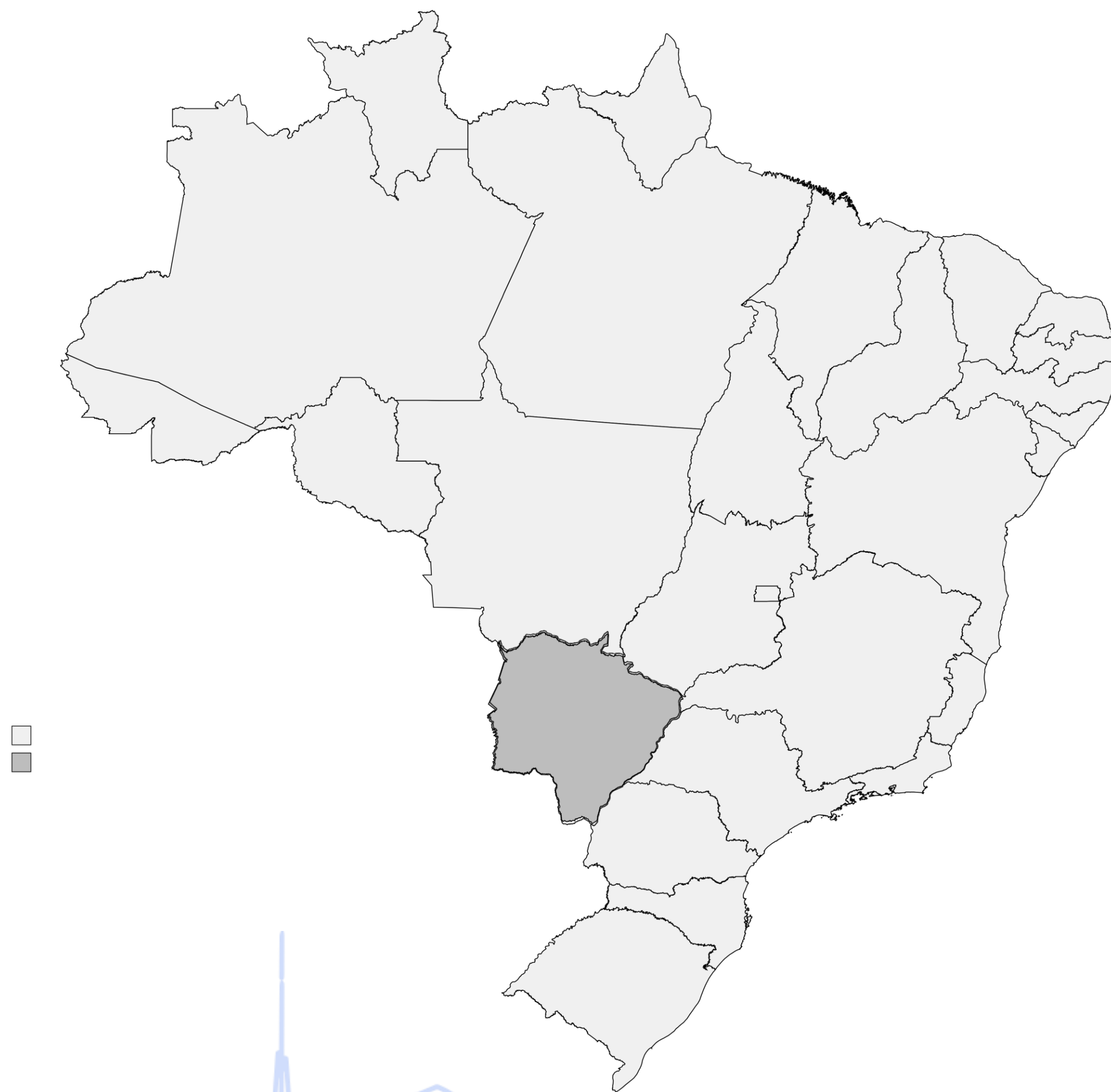

ORGANIZAÇÃO

10

Postos Fiscais Divisas

03

Postos Fiscais Urbanos

03

Unidades de Fiscalização de Transportadoras

03

Regionais de Fiscalização Móvel

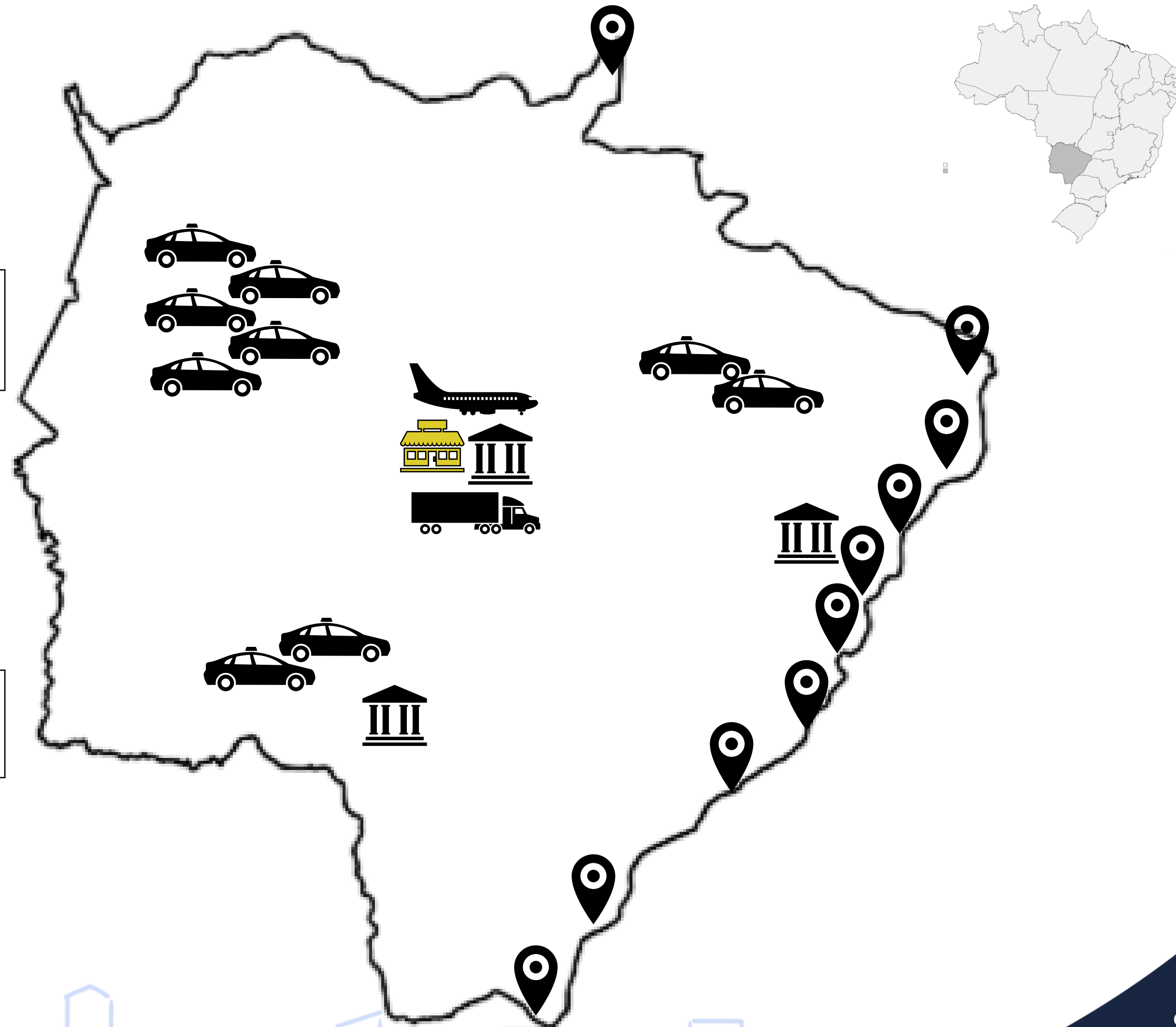



ASSEGURAR A REGULARIDADES FORMAL DAS OPERAÇÃO (DFe, Origem, Destino)

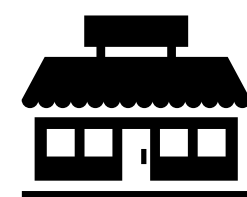

ASSEGURAR A REGULARIDADE CADASTRAL DOS CONTRIBUINTES



GARANTIR A EXIGÊNCIA DO CRÉDITO TRIBUTÁRIO DEVIDO NA OPERAÇÃO



ASSEGURAR A CONFORMIDADE FÍSICA DAS CARGAS E MERCADORIAS



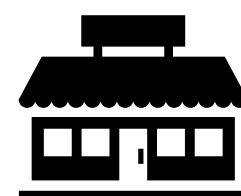

ARRECADAÇÃO DIRETA

PRESENÇA FISCAL
(PERCEPÇÃO DE RISCO)

ARRECADAÇÃO
INDIRETA



VEÍCULOS ABORDADOS

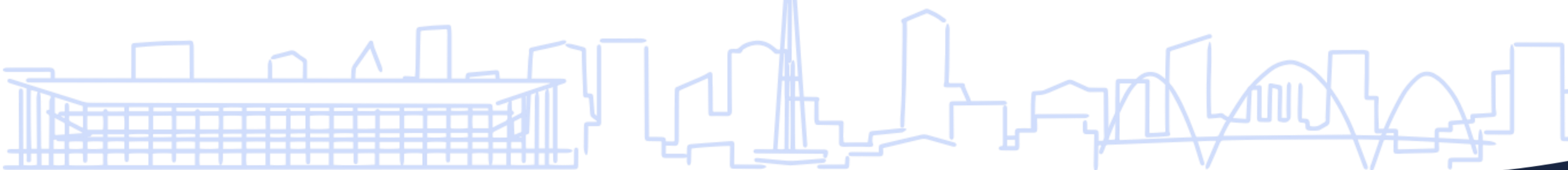
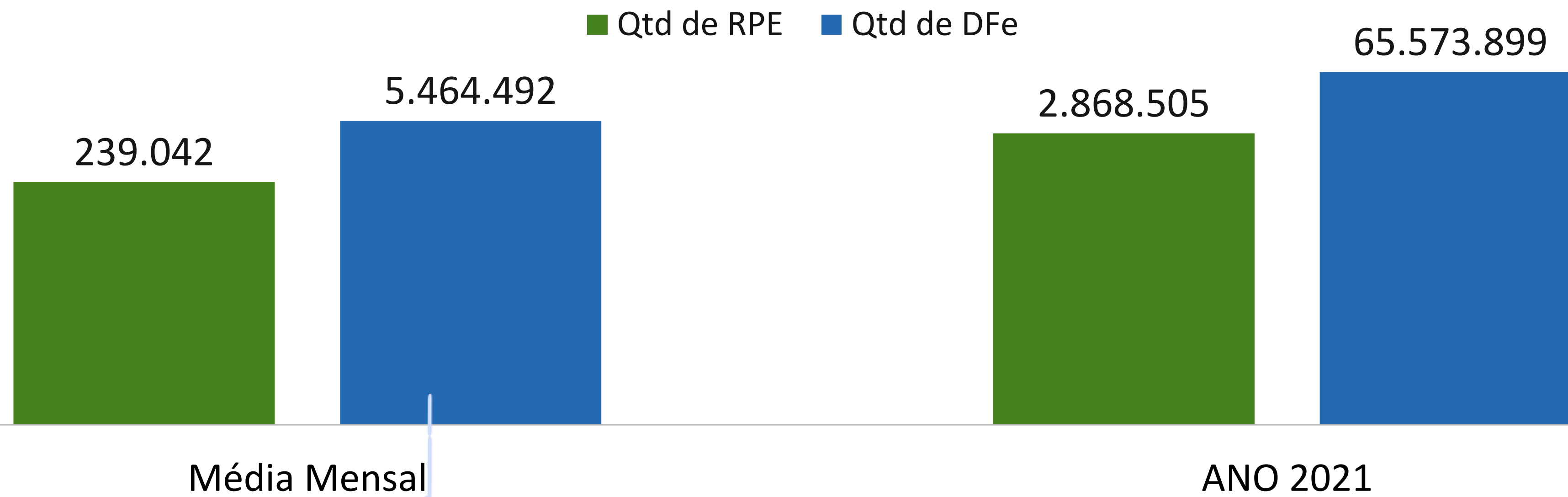

DF-es FISCALIZADOS

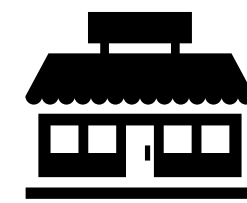

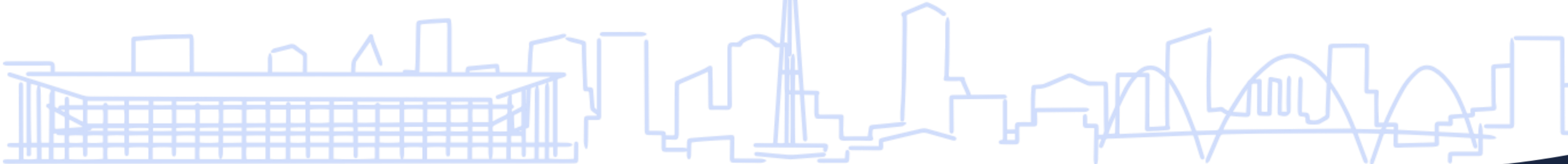
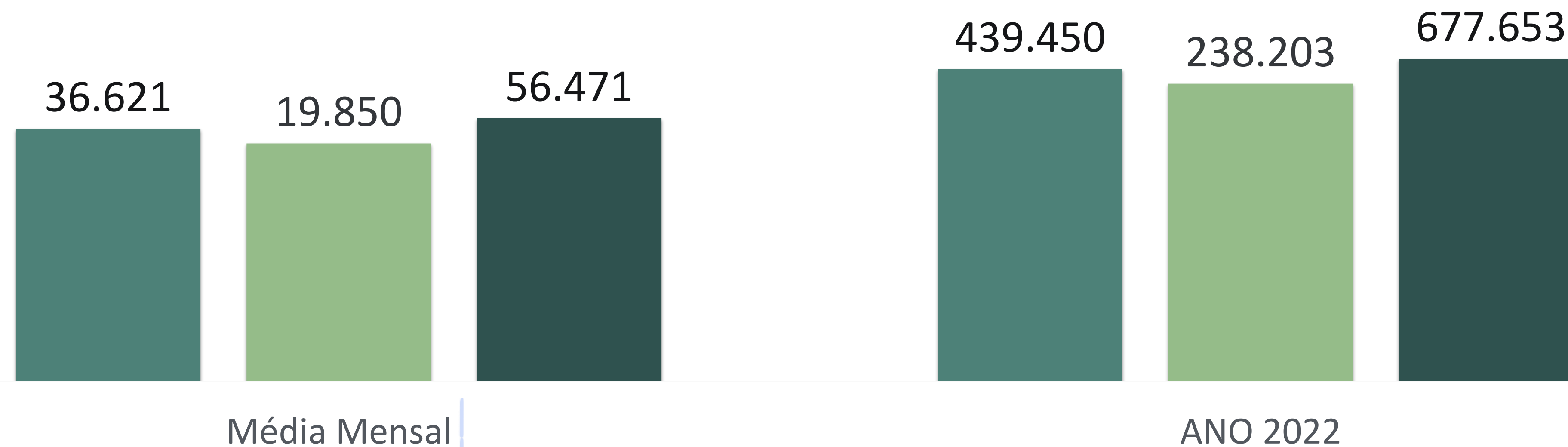

CONTRIBUINTES NOTIFICADOS

■ TERMOS FISCAIS (TVF/TA) ■ DAEMS Notificados ■ TOTAL



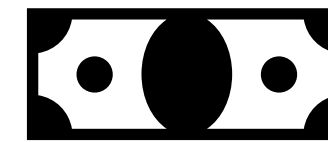

Créditos Tributários Exigidos (ARRECADAÇÃO DIRETA)

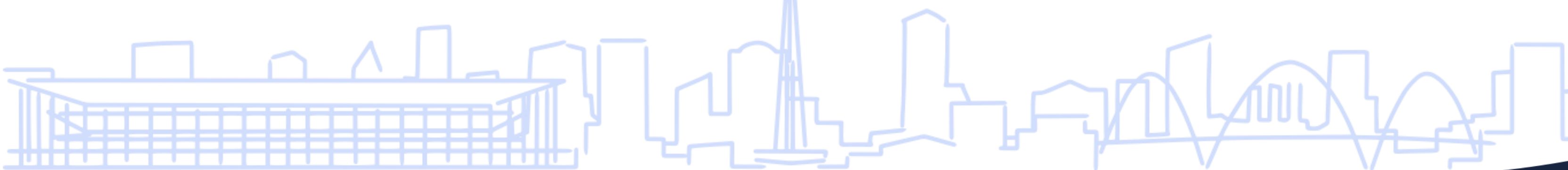
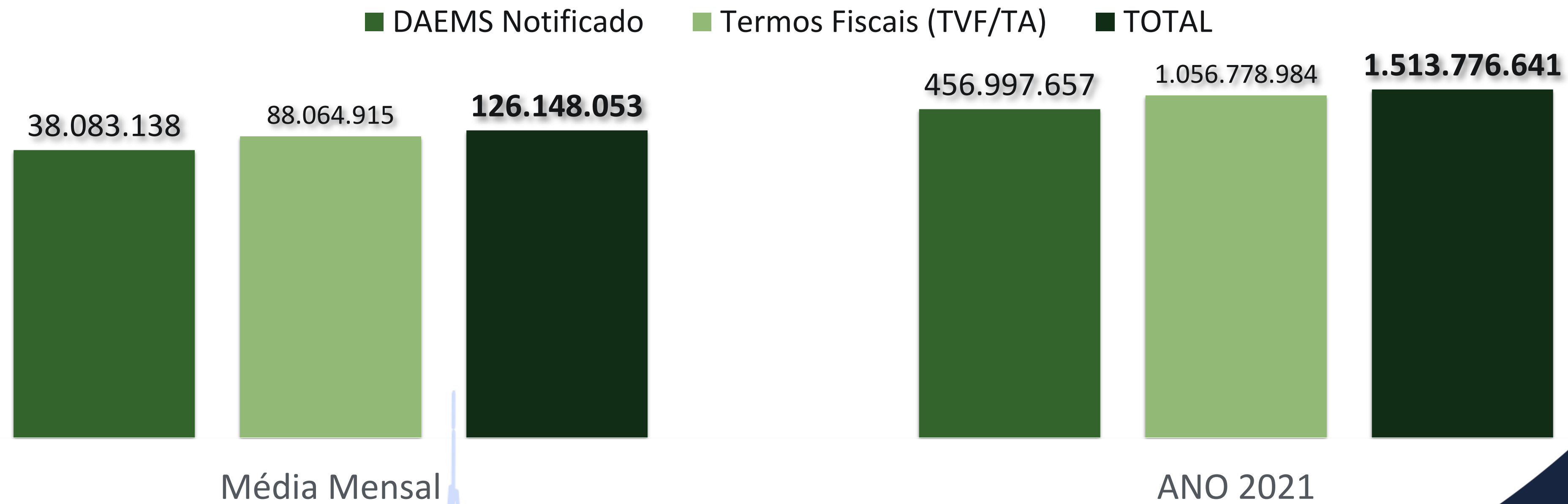

MOCKUP PROCESSO TRADICIONAL

PARADA OBRIGATÓRIA

Emite DF-e

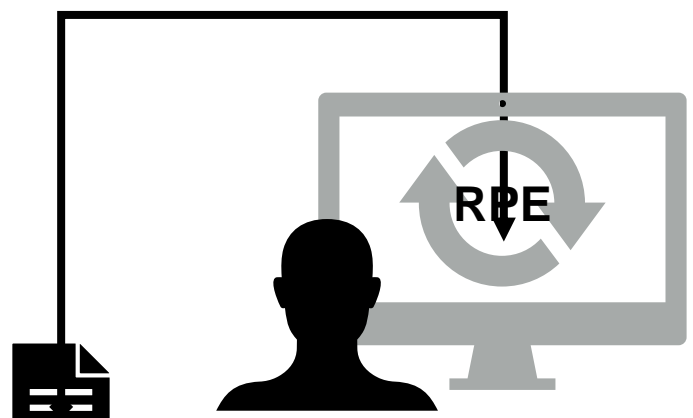

Processamento de Indício



Fiscal



Fiscalização Documental

Fiscalização Física



- Análise DF-e
- Classifica NF-e
- Fiscaliza a Carga
- Emite Termos c/ exigência
- Finaliza RPE





"MODERNIZAR A FISCALIZAÇÃO DE
MERCADORIAS EM TRÂNSITO"

U\$ 8.700.000

Sistema de Fiscalização de Mercadorias
em Trânsito baseado em análise de
risco

- Exigir o ICMS quando devido em cada operação;
- Assegurar que a mercadoria possua documentos fiscal (NF-e, CT-e, MDF-e);
- Impedir a reutilização de documentos fiscal;
- Controlar Entradas e Saídas de mercadorias do Estado;
- Manter a percepção de risco pelo contribuinte para estimular adimplemento voluntário das obrigações tributárias;
- Coibir a simulação de operações com mercadorias;
- Possibilitar a intervenção imediata do Fisco no controle de Regimes, IE irregulares, Importações, Exportações, (Instrumento de Presença do Fisco).

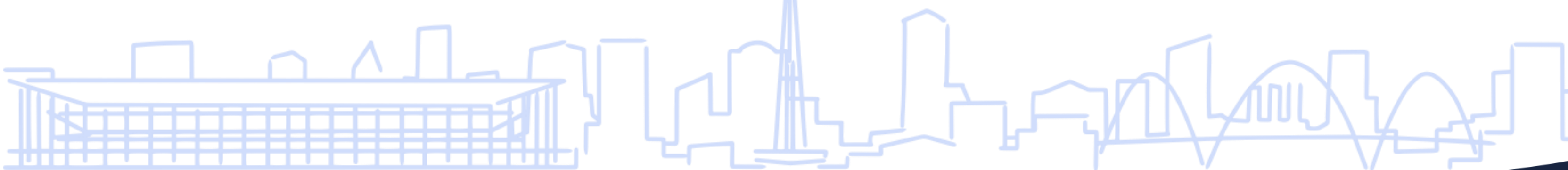

PROBLEMÁTICA

- Modelo de fiscalização baseado na PARADA OBRIGATÓRIA de todos os veículos de cargas e na retenção das mercadorias;
- Baixo uso de tecnologias modernas nos processos;
- Ausência de critério de seletividade;
- Impacto na logística dos transportadores e contribuintes;
- Servidores pressionados pelo volume de trabalho (estresse);
- Baixa prioridade para fiscalização física;
- Baixa eficiência de controle e de assertividade;
- Filas em rodovias.



- Racionalizar o esforço fiscal;
- Melhorar assertividade;
- Aumentar a eficiência no controle;
- Não onerar o serviço de transporte de cargas;
- Acabar com filas nas rodovias;
- Contribuir com agilidade no transporte das mercadorias;
- Desburocratizar os procedimentos de fiscalização;
- Não interferir nas operações regulares;
- Despressurizar o ambiente de trabalho.

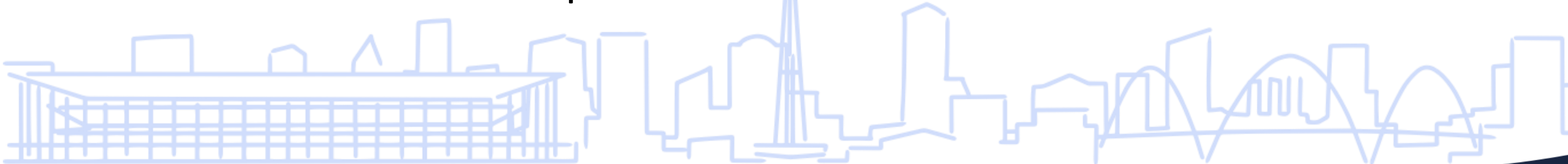

INOVAÇÃO

Processos
Tecnologia
Organização
Pessoas



CONCEITO DO NOVO MODELO

- PRF
- DETRAN
- WAY
- IAGRO
- CCRMSVias
- SEJUSP

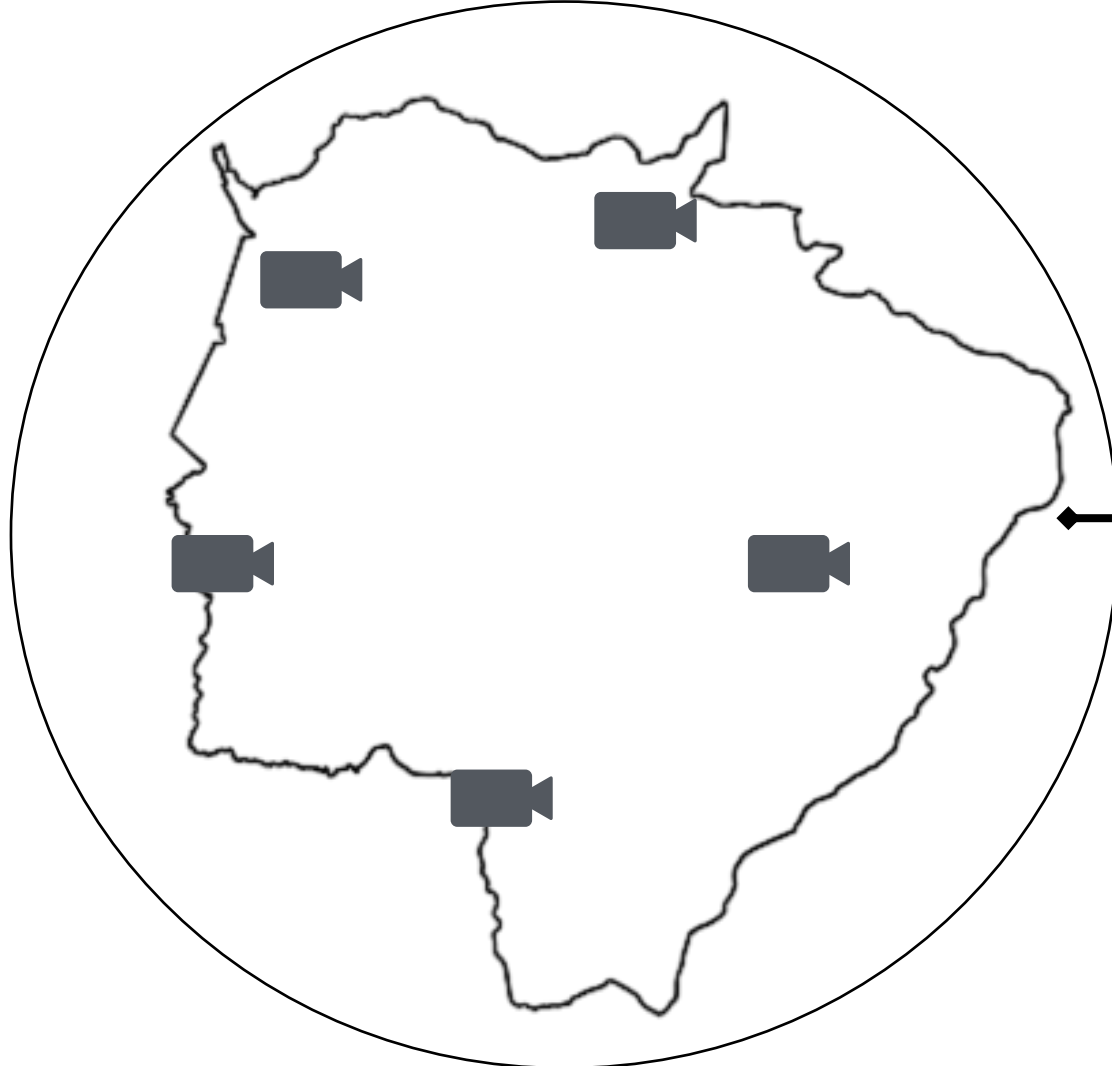

OCRs (SEFAZ e ACTs)

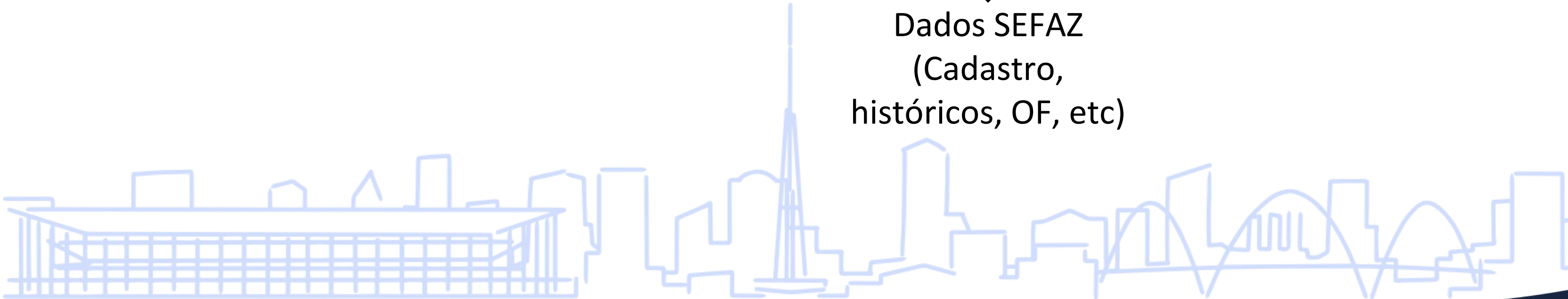
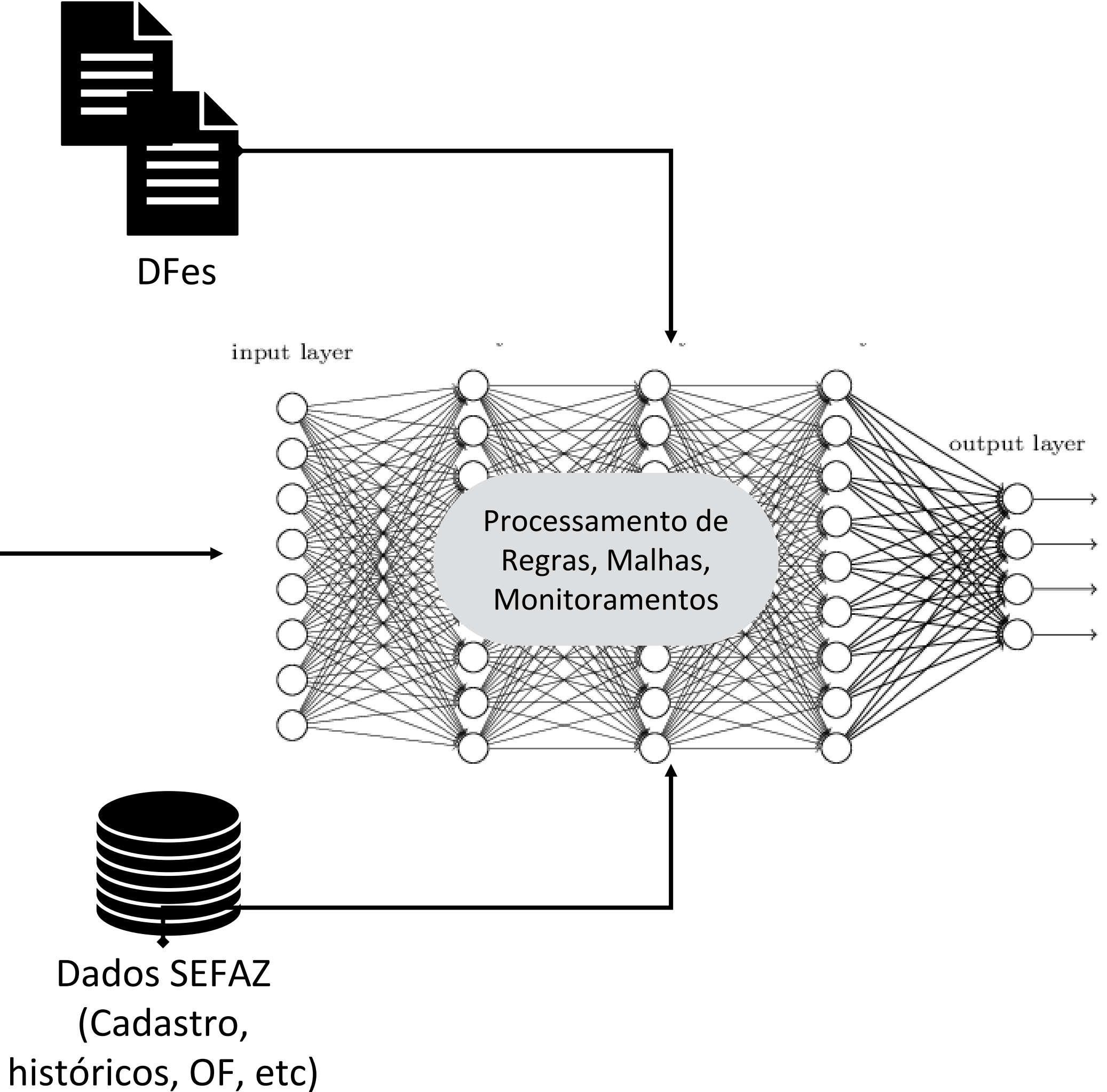

CONCEITO DO NOVO MODELO

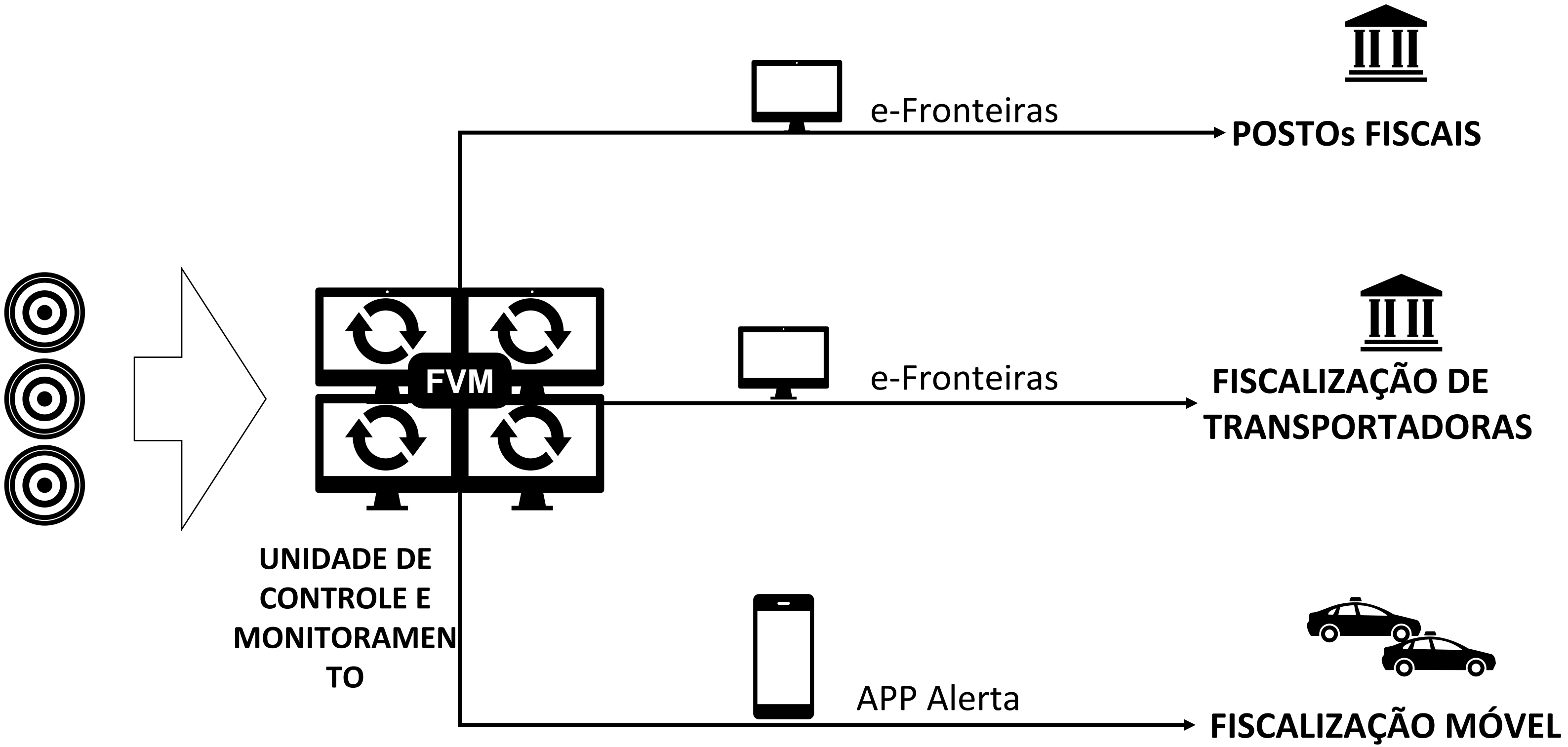

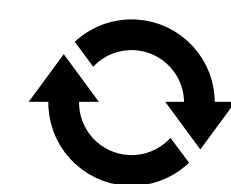

Processamento de indício



Fiscalização Documental



Fiscalização Física



INOVAÇÃO DO PROCESSO DE FISCALIZAÇÃO



VPA-VERIFICAÇÃO EM PROCESSO
ANTECIPADO

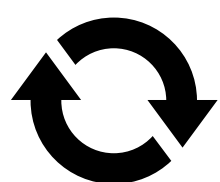

Processamento
de indício
(VPA)



POSTO FISCAL (10)



Fiscalização Física

Análise DF-e
Fiscaliza a Carga
Emite Termos c/ exigência



POSTO FISCAL VIRTUAL (1)



Fiscalização Documental

Análise DF-e
Classifica NF-e
Emite Termos c/ exigência
Finaliza RPE



Posto Fiscais Divisas

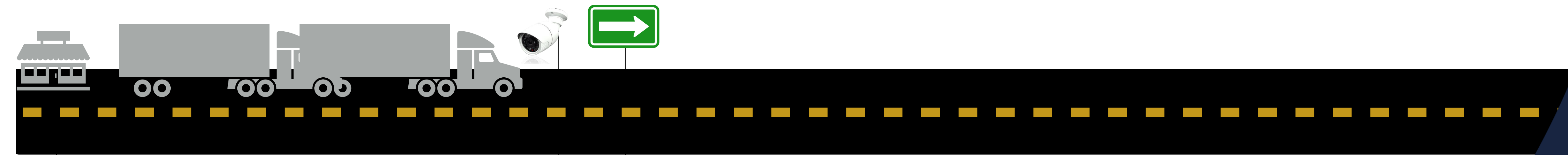

Emite DF-e

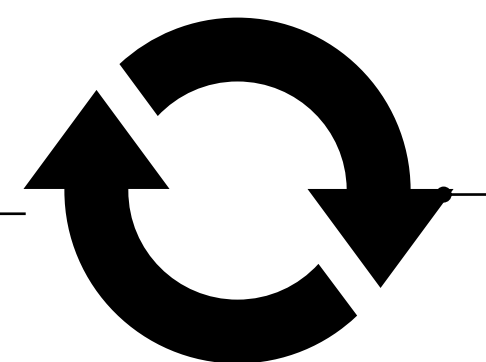

VPA (app)

Tabela de Ordem de Parada



POSTO FISCAL VIRTUAL

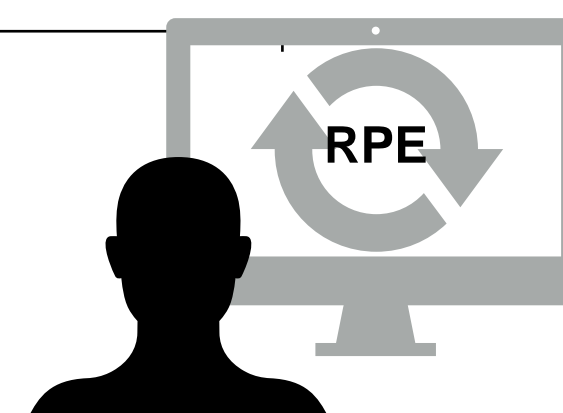

Fiscal

- Análise DF-e
- Classifica NF-e
- Aciona UCOMT/Móvel
- Emite Termos/Notificação
- Finaliza RPE

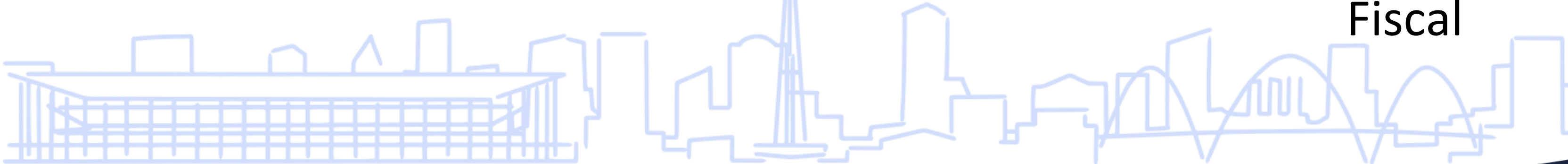



Posto Fiscais Divisas

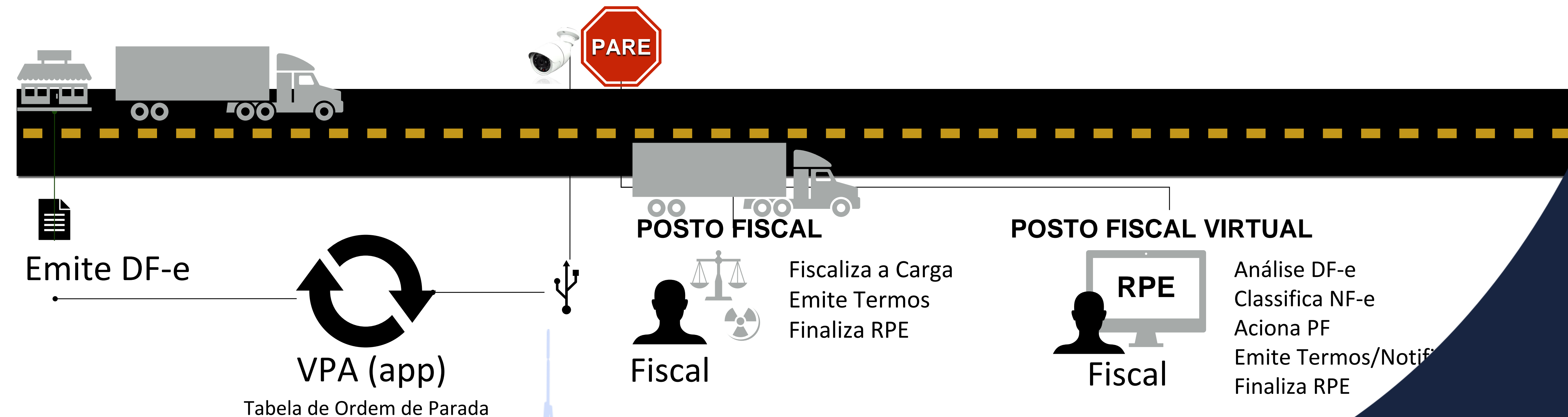

- Fiscalização de preditiva (proativa);
- PARADA de veículos de cargas com a partir de INDÍCIOS de IRREGULARIDADE ;
- Uso das novas tecnologias (IA, Big Data, câmeras OCR, veículo escâner, pesagem dinâmica, etc);
- Controle Interestadual com MAIOR EFETIVIDADE;
- Modelo que ESTIMULE e PREMIE o bom contribuinte;
- Controle mais efetivo e EFICIENTE das evasões;
- Mantém abrangência de atuação e consequente presença fiscal.



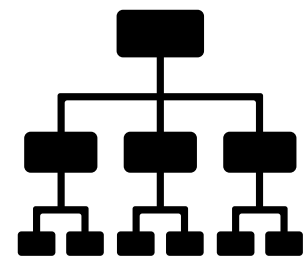

ESTRUTURA

- Reforma e Remodelagem dos Postos Fiscais: Canal SEM PARAR; **(BID)**
- Estruturação da UCOMT ;
- 63 pontos de Capturas de OCR; **(BID)**
- 02 Veículos Scanner de Cargas; **(BID)**
- Balanças para PFs;
- Equipamentos e Instrumentos; **(BID)**
- PMVs; **(BID)**

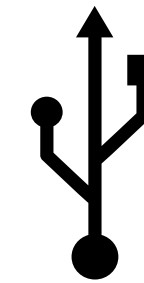

TECNOLOGIA

- Remodelagem do e-Fronteiras; **(BID)**
- Tratamento e Integração de dados das OCRs.; **(BID)**
- Sistema ALERTA (APP); **(BID)**
- Malhas Fiscais de Direcionamento da Fiscalização de MTR; **(BID)**
- ACT com PRF, IAGRO, SEJUSP, WAY, CCRMSVias, DETRAN

RESULTADOS APURADOS



10 meses
Posto Fiscal Virtual

06 meses
FREE FLOW

56º COGEF
Comissão de Gestão Fazendária

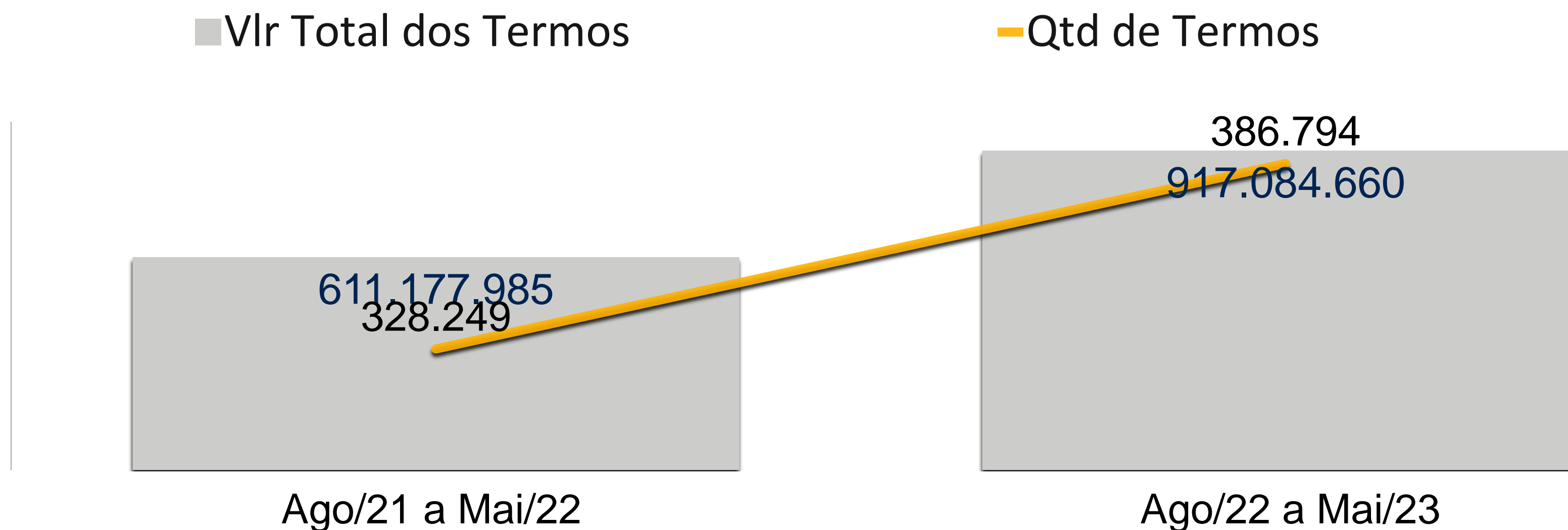

Aumento **17% no volume** de **46% no valor** da exigência de crédito tributário



10 meses
Posto Fiscal Virtual

06 meses
FREE FLOW

	Free Flow	Demais PFs
Veículo Liberado	175.524	1.613.924
Veículo Não Liberado	61.839	698.458

Redução do **tempo de permanência de 70%** dos veículos de carga e **desobrigação**
175.000 paradas em PFs

Extinção das filas em postos fiscais

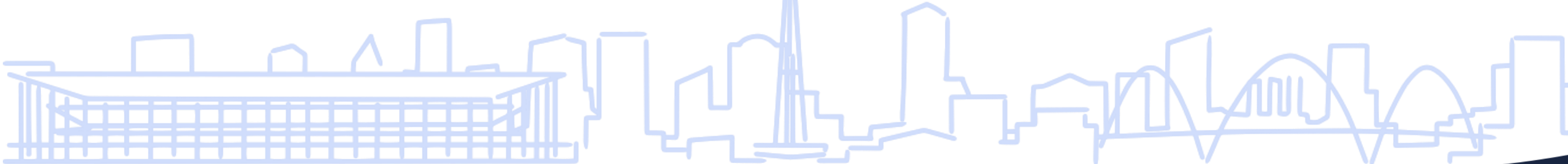

CRONOGRAMA

Metodologia PF	Concluído	Ago/22
PF VIRTUAL	Concluído	Ago/22
FREE FLOW (CCR, ENCAT)	Em Expansão	Dez/23
Câmeras OCR	Em Expansão	Ago/23
Integração dados OCRs	Concluído	Mai/23
Hardware Canal (PMVs)	Em Licitação	Out/23

E-Fronteiras (VPA)	Concluído	Mai/23
E-Fronteiras (FVM)	Desenvolvimento	Dez/23
Veículos Escâner	Em Licitação	Ago/24
Projetos Reformas PF	Concluído	Mai/23
Reformas PF (Execução)	Em Licitação	Abr/24
Balanças	À Licitar	

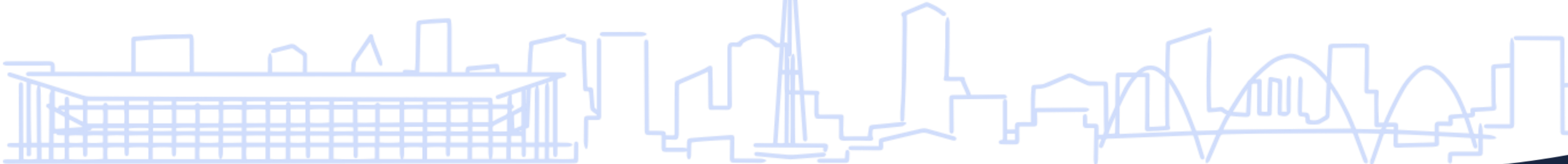

Estudos de Inteligência Artificial (IA)



Posto Fiscal Virtual

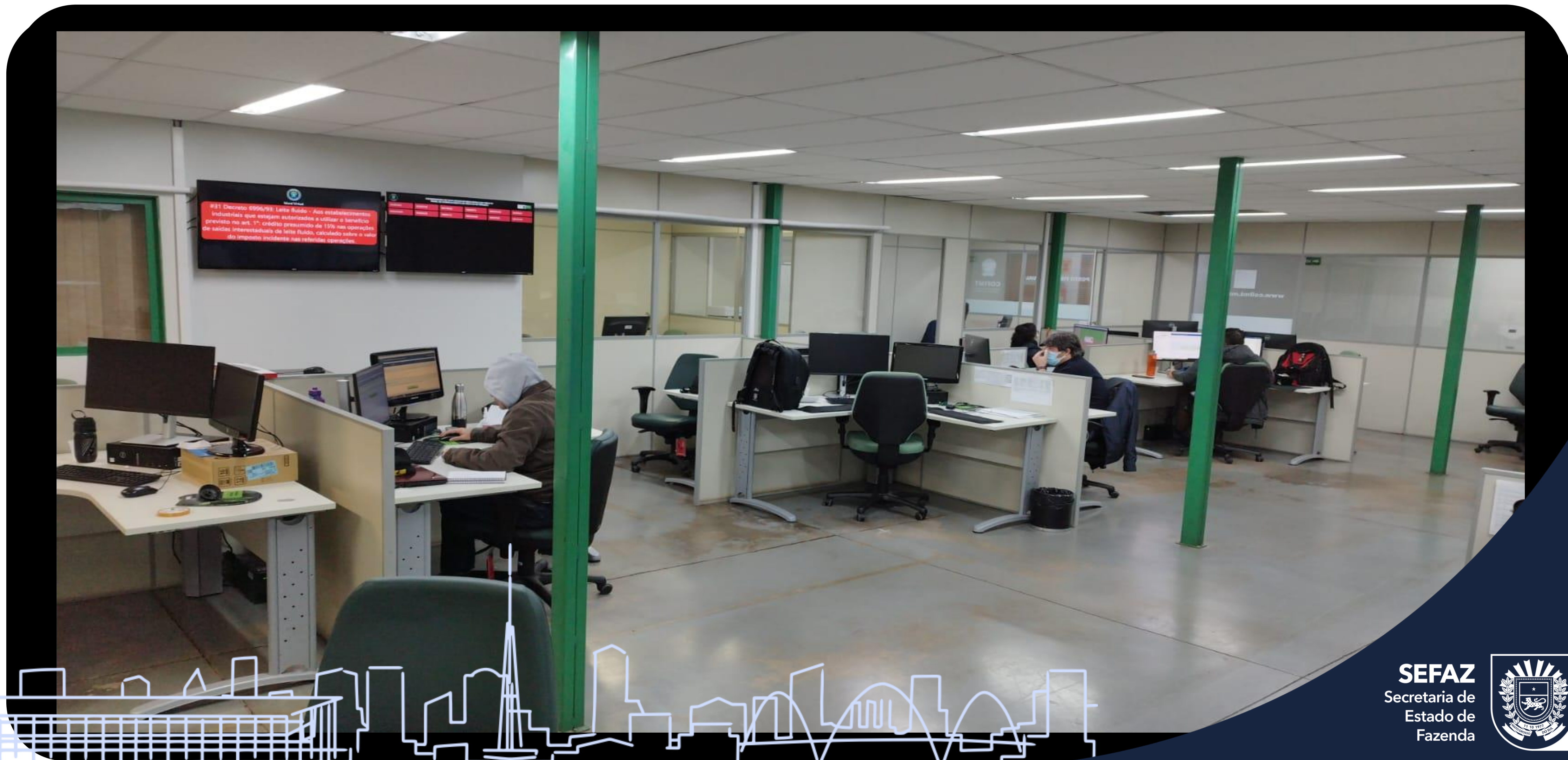

FREE FLOW



FREE FLOW

E-CAP
UNI
FICA
DO



com áreas no mesmo município.



Coordenadoria de Fiscalização de
Mercadorias em Trânsito

Rubens Soares de França

Fiscal Tributário Estadual
Coordenador de Fiscalização
de Mercadorias em Trânsito

rfranca@fazenda.ms.gov.br

Fone: (67) 3318-3161 / (67) 99223-8835



Coordenadoria Especial de
Tecnologia da Informação

56ª COGEF
Comissão de Gestão Fazendária

SEFAZ
Secretaria de
Estado de
Fazenda



GOVERNO DE
Mato
Grosso
do Sul